

Nedsonic®

Measuring clamp load using ultrasonic waves



Bolts can be tightened in different ways, but in the end, one thing is most important: clamp load. To ensure our bolts hold components together, we tighten them to generate clamp load. This tightening causes the bolts to elongate. By sending an ultrasonic wave into the bolt and recording the duration of the wave's travel, the length of the bolt can be determined. Comparing this value with the original length of the product means the elongation can be derived. Since there's a linear dependency between the clamp load of a bolt and its elongation, the clamp load can be calculated very accurately.

Nedschroef developed Nedsonic® bolts, they allow you to perform these ultrasonic measurements without any special preparation of the bolt. With using ultrasonic measuring in combination with Nedsonic® bolts, the reliability of tightening can be increased. Tightening technology now has - besides torque and angle - a third measured signal: the clamp load.

Field of application

Certain connections are critical, such as the connection between the cylinder head and the engine block fixings in the wheel suspension or mounting the axle to the body. Nedsonic® bolts can be used in these applications to make sure that after tightening of the bolt the clamp load can be checked, regardless of the tightening technique employed.

For more information: www.nedschroef.com

 **NEDSCHROEF**

one step ahead...

Ultrasonic Tightening Bolt

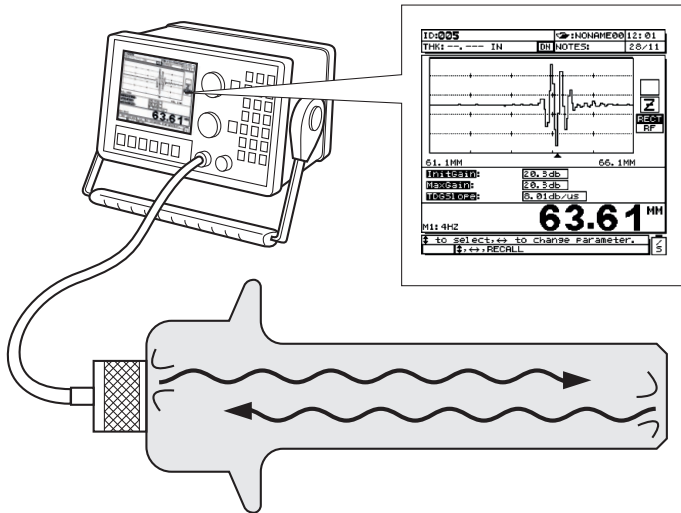

$\text{Length} = \frac{1}{2} \times \text{time of flight} \times \text{speed of sound in bolt}$

Dimensions

- All bolts M8 and larger with external drives
- All property classes

Limitations

The Nedsonic® feature is less usable for bolts with an inner drive and small diameters (< M8) and cannot be combined with special tips of the bolts like Nedpoint.

Properties

In order for the ultrasonic sound wave to be able to travel through the bolt there are a few requirements.

- Flat surface on the bolts head, which is parallel to the special reflection tip at the bolts end
- Special reflection tip at the bolts end, which not only has a flat surface but also sharp edges to ensure that the reflection area is the only area that reflects the ultrasonic signal straight back to the head of the bolt
- The threaded length of the bolt needs to be at least half of the total length of the product (including the head height)

Advantages

- Evaluate and indicate the achieved clamp load
- Guarantee a reliable and profound clamp load documentation
- Opportunity to check bolts if torque checking is impossible (e.g. micro-encapsulated bolts)
- Reduction of the amount of test and calibration work
- Improved quality and reliability of the products
- Reduced warranty and repair costs
- Reduced call back and product liability costs

Axle mounting

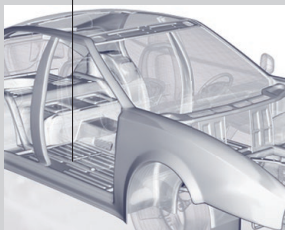

Cylinder head

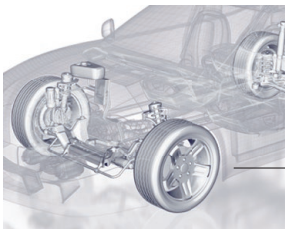
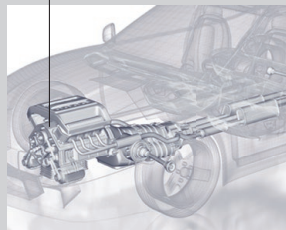

Wheel suspension



Koninklijke Nedschroef Holding
Kanaaldijk N.W. 75
P.O. Box 548
5700 AM Helmond
The Netherlands
T +31 492 588 556
F +31 492 548 084
E holding@nedschroef.com

www.nedschroef.com

Follow us:



For over a century, Koninklijke Nedschroef Holding B.V. has developed, manufactured and supplied fasteners and special parts for the automotive industry. In addition, we design and produce superior forming machines and tools for the metal forming industry.

Nedschroef delivers world-class services and innovative, cost-effective solutions. Our expanding global operations offer everything from product design and development to delivery, installation and service, supported by a vast global partner network. 1,600 people at 24 facilities, including six centres of competence, in 14 countries worldwide are committed to our Full Service Provision concept.